

Reference  
Guide

Keysight M9451A  
DPD/ET  
Measurement  
Accelerator



# Notices

## Copyright Notice

© Keysight Technologies 2015

No part of this manual may be reproduced in any form or by any means (including electronic storage and retrieval or translation into a foreign language) without prior agreement and written consent from Keysight Technologies, Inc. as governed by United States and international copyright laws.

## Manual Part Number

M9451-90004

## Published By

Keysight Technologies  
Ground Floor and Second Floor, CP-11  
Sector-8, IMT Manesar – 122051  
Gurgaon, Haryana, India

## Edition

Edition 2, August, 2015  
Printed In Malaysia

## Regulatory Compliance

This product has been designed and tested in accordance with accepted industry standards, and has been supplied in a safe condition. To review the Declaration of Conformity, go to <http://www.keysight.com/go/conformity>.

## Warranty

THE MATERIAL CONTAINED IN THIS DOCUMENT IS PROVIDED “AS IS,” AND IS SUBJECT TO BEING CHANGED, WITHOUT NOTICE, IN FUTURE EDITIONS. FURTHER, TO THE MAXIMUM EXTENT PERMITTED BY APPLICABLE LAW, KEYSIGHT DISCLAIMS ALL WARRANTIES, EITHER EXPRESS OR IMPLIED, WITH REGARD TO THIS MANUAL AND ANY INFORMATION CONTAINED HEREIN, INCLUDING BUT NOT LIMITED TO THE IMPLIED WARRANTIES OF MERCHANTABILITY AND FITNESS FOR A PARTICULAR PURPOSE. KEYSIGHT SHALL NOT BE LIABLE FOR ERRORS OR FOR INCIDENTAL OR CONSEQUENTIAL DAMAGES IN CONNECTION WITH THE

FURNISHING, USE, OR PERFORMANCE OF THIS DOCUMENT OR OF ANY INFORMATION CONTAINED HEREIN. SHOULD KEYSIGHT AND THE USER HAVE A SEPARATE WRITTEN AGREEMENT WITH WARRANTY TERMS COVERING THE MATERIAL IN THIS DOCUMENT THAT CONFLICT WITH THESE TERMS, THE WARRANTY TERMS IN THE SEPARATE AGREEMENT SHALL CONTROL. KEYSIGHT TECHNOLOGIES DOES NOT WARRANT THIRD-PARTY SYSTEM-LEVEL (COMBINATION OF CHASSIS, CONTROLLERS, MODULES, ETC.) PERFORMANCE, SAFETY, OR REGULATORY COMPLIANCE, UNLESS SPECIFICALLY STATED.

## Technology Licenses

The hardware and/or software described in this document are furnished under a license and may be used or copied only in accordance with the terms of such license.

## U.S. Government Rights

The Software is “commercial computer software,” as defined by Federal Acquisition Regulation (“FAR”) 2.101. Pursuant to FAR 12.212 and 27.405-3 and Department of Defense FAR Supplement (“DFARS”) 227.7202, the U.S. government acquires commercial computer software under the same terms by which the software is customarily provided to the public. Accordingly, Keysight provides the Software to U.S. government customers under its standard commercial license, which is embodied in its End User License Agreement (EULA), a copy of which can be found at <http://www.keysight.com/find/sweula>. The license set forth in the EULA represents the exclusive authority by which the U.S. government may use, modify, distribute, or disclose the Software. The EULA and the license set forth therein, does not require or permit, among other things, that Keysight: (1) Furnish technical information related to commercial computer software or commercial computer software documentation that is not customarily provided to the public; or (2) Relinquish

to, or otherwise provide, the government rights in excess of these rights customarily provided to the public to use, modify, reproduce, release, perform, display, or disclose commercial computer software or commercial computer software documentation. No additional government requirements beyond those set forth in the EULA shall apply, except to the extent that those terms, rights, or licenses are explicitly required from all providers of commercial computer software pursuant to the FAR and the DFARS and are set forth specifically in writing elsewhere in the EULA. Keysight shall be under no obligation to update, revise or otherwise modify the Software. With respect to any technical data as defined by FAR 2.101, pursuant to FAR 12.211 and 27.404.2 and DFARS 227.7102, the U.S. government acquires no greater than Limited Rights as defined in FAR 27.401 or DFAR 227.7103-5 (c), as applicable in any technical data.

## Safety Notices

### CAUTION

A CAUTION notice denotes a hazard. It calls attention to an operating procedure, practice, or the like that, if not correctly performed or adhered to, could result in damage to the product or loss of important data. Do not proceed beyond a CAUTION notice until the indicated conditions are fully understood and met.

### WARNING

A WARNING notice denotes a hazard. It calls attention to an operating procedure, practice, or the like that, if not correctly performed or adhered to, could result in personal injury or death. Do not proceed beyond a WARNING notice until the indicated conditions are fully understood and met.

The following safety precautions should be observed before using this product and any associated instrumentation.

This product is intended for use by qualified personnel who recognize

shock hazards and are familiar with the safety precautions required to avoid possible injury. Read and follow all installation, operation, and maintenance information carefully before using the product.

### WARNING

If this product is not used as specified, the protection provided by the equipment could be impaired. This product must be used in a normal condition (in which all means for protection are intact) only.

The types of product users are:

- Responsible body is the individual or group responsible for the use and maintenance of equipment, for ensuring that the equipment is operated within its specifications and operating limits, and for ensuring operators are adequately trained.
- Operators use the product for its intended function. They must be trained in electrical safety procedures and proper use of the instrument. They must be protected from electric shock and contact with hazardous live circuits.
- Maintenance personnel perform routine procedures on the product to keep it operating properly (for example, setting the line voltage or replacing consumable materials). Maintenance procedures are described in the user documentation. The procedures explicitly state if the operator may perform them. Otherwise, they should be performed only by service personnel.
- Service personnel are trained to work on live circuits, perform safe installations, and repair products. Only properly trained service personnel may perform installation and service procedures.

### WARNING

Operator is responsible to maintain safe operating conditions. To ensure safe operating conditions, modules should not be operated beyond the full temperature range specified in the Environmental and physical specification. Exceeding safe operating conditions can result in shorter lifespans, improper module

performance and user safety issues. When the modules are in use and operation within the specified full temperature range is not maintained, module surface temperatures may exceed safe handling conditions which can cause discomfort or burns if touched. In the event of a module exceeding the full temperature range, always allow the module to cool before touching or removing modules from chassis.

Keysight products are designed for use with electrical signals that are rated Measurement Category I and Measurement Category II, as described in the International Electrotechnical Commission (IEC) Standard IEC 60664. Most measurement, control, and data I/O signals are Measurement Category I and must not be directly connected to mains voltage or to voltage sources with high transient over-voltages. Measurement Category II connections require protection for high transient over-voltages often associated with local AC mains connections. Assume all measurement, control, and data I/O connections are for connection to Category I sources unless otherwise marked or described in the user documentation.

Exercise extreme caution when a shock hazard is present. Lethal voltage may be present on cable connector jacks or test fixtures. The American National Standards Institute (ANSI) states that a shock hazard exists when voltage levels greater than 30V RMS, 42.4V peak, or 60VDC are present. A good safety practice is to expect that hazardous voltage is present in any unknown circuit before measuring.

Operators of this product must be protected from electric shock at all times. The responsible body must ensure that operators are prevented access and/or insulated from every connection point. In some cases, connections must be exposed to potential human contact. Product operators in these circumstances must be trained to protect themselves from the risk of electric shock. If the circuit is capable of operating at or above 1000V,

no conductive part of the circuit may be exposed.

Do not connect switching cards directly to unlimited power circuits. They are intended to be used with impedance-limited sources. NEVER connect switching cards directly to AC mains. When connecting sources to switching cards, install protective devices to limit fault current and voltage to the card.

Before operating an instrument, ensure that the line cord is connected to a properly-grounded power receptacle. Inspect the connecting cables, test leads, and jumpers for possible wear, cracks, or breaks before each use.

When installing equipment where access to the main power cord is restricted, such as rack mounting, a separate main input power disconnect device must be provided in close proximity to the equipment and within easy reach of the operator.

For maximum safety, do not touch the product, test cables, or any other instruments while power is applied to the circuit under test. ALWAYS remove power from the entire test system and discharge any capacitors before: connecting or disconnecting cables or jumpers, installing or removing switching cards, or making internal changes, such as installing or removing jumpers.

Do not touch any object that could provide a current path to the common side of the circuit under test or power line (earth) ground. Always make measurements with dry hands while standing on a dry, insulated surface capable of withstanding the voltage being measured.

The instrument and accessories must be used in accordance with its specifications and operating instructions, or the safety of the equipment may be impaired.

Do not exceed the maximum signal levels of the instruments and accessories, as defined in the specifications and operating information, and as shown on the instrument or test fixture panels, or switching card.

When fuses are used in a product, replace with the same type and rating for continued protection against fire hazard.

Chassis connections must only be used as shield connections for measuring circuits, NOT as safety earth ground connections.

If you are using a test fixture, keep the lid closed while power is applied to the device under test. Safe operation requires the use of a lid interlock.

Instrumentation and accessories shall not be connected to humans.

Before performing any maintenance, disconnect the line cord and all test cables.

To maintain protection from electric shock and fire, replacement components in mains circuits – including the power transformer, test leads, and input jacks – must be purchased from Keysight. Standard fuses with applicable national safety approvals may be used if the rating and type are the same. Other components that are not safety-related may be purchased from other suppliers as long as they are equivalent to the original component (note that selected parts should be purchased only through Keysight to maintain accuracy and functionality of the product). If you are unsure about the applicability of a replacement component, call an Keysight office for information.

### WARNING

No operator serviceable parts inside. Refer servicing to qualified personnel. To prevent electrical shock do not remove covers. For continued protection against fire hazard, replace fuse with same type and rating.

### PRODUCT MARKINGS:



The CE mark is a registered trademark of the European Community.



Australian Communication and Media Authority mark to indicate regulatory compliance as a registered supplier.



This symbol indicates product compliance with the Canadian Interference-Causing Equipment Standard (ICES-001). It also identifies the product is an Industrial Scientific and Medical Group 1 Class A product (CISPR 11, Clause 4).



South Korean Class A EMC Declaration. This equipment is Class A suitable for professional use and is for use in electromagnetic environments outside of the home. A 급 기기 (업무용 방송통신기자재) 이 기기는 업무용 (A 급) 전자파적합기기로서 판매자 또는 사용자는 이 점을 주의하시기 바라며, 가정외의 지역에서 사용하는 것을 목적으로 합니다.



This product complies with the WEEE Directive marketing requirement. The affixed product label (above) indicates that you must not discard this electrical/electronic product in domestic household waste. **Product Category:** With reference to the equipment types in the WEEE directive Annex 1, this product is classified as “Monitoring and Control instrumentation” product. Do not dispose in domestic household waste. To return unwanted products, contact your local Keysight office, or for more information see <http://about.keysight.com/en/companyinfo/environment/takeback.shtml>.



This symbol indicates the instrument is sensitive to electrostatic discharge (ESD). ESD can damage the highly sensitive components in your instrument. ESD damage is most likely to occur as the module is being installed or when cables are connected or disconnected. Protect the circuits from ESD damage by wearing a grounding strap that provides a high resistance path to ground. Alternatively, ground yourself to discharge any built-up static charge by touching the outer shell of any grounded instrument chassis before touching the port connectors.



This symbol on an instrument means caution, risk of danger. You should refer to the operating instructions located in the user documentation in all cases where the symbol is marked on the instrument.



This symbol indicates the time period during which no hazardous or toxic substance elements are expected to leak or deteriorate during normal use. Forty years is the expected useful life of the product.

### CLEANING PRECAUTIONS:

#### WARNING

To prevent electrical shock, disconnect the Keysight Technologies instrument from mains before cleaning. Use a dry cloth or one slightly dampened with water to clean the external case parts. Do not attempt to clean internally. To clean the connectors, use alcohol in a well-ventilated area. Allow all residual alcohol moisture to evaporate, and the fumes to dissipate prior to energizing the instrument.



# Contents

Introduction .....	9
Concepts .....	9
Envelope Tracking (ET) Concept .....	10
Reasons to Use Envelope Tracking .....	10
Envelope Tracking Basic Concept .....	11
Digital Pre-Distortion (DPD) Concept .....	12
DPD Implementation Methods .....	13
M9451A-DPD/ET Block Diagram .....	17
Data Interfaces .....	18
Reference IQ Data .....	18
Measured PA Output Data using Test Equipment .....	19
M9451A DPD/ET Measurements .....	19
DPD Output .....	19
Envelope Data .....	19
M9451A-DPD/ET Specifications .....	21
Programming M9451A-DPD/ET option using .NET and IVI APIs .....	23
Using API Help .....	23
Example Programs .....	23
Numeric Format .....	23
Language Requirements .....	24
References .....	24
Sample API Programs .....	24
C# (C Sharp) Example Programs .....	25
CS_PredistortExample – Digital Pre-Distortion Example .....	25
CS_LutDpdExample – Look-up Table DPD example, using peer-to-peer data transfer .....	25
CS_LutDpdExampleNoPTP – Look-up Table DPD example, not using peer-to-peer data transfer .....	25
CS_MemoryModelDpdExample – Memory Model DPD example .....	25
CS_EnvelopeTrackingExample – Envelope Tracking example .....	26
CS_DpdFileViewer – Graphical Viewer Utility .....	26
Troubleshooting M9451A DPD/ET Measurement Accelerator .....	29
Optimizing Performance .....	31





## Introduction

The scope of this Guide is to detail the concepts and processes involved in conducting measurements using the DPD/ET option of Keysight M9451A PXIe Measurement Accelerator. The DPD option of Keysight M9451A PXIe Measurement Accelerator allows you to use the closed DPD/ET acceleration engine and perform fast DPD/ET measurements using a Keysight FPGA image with hardware that supports peer-to-peer transfers. If you have any questions after reviewing this information, please contact your local Keysight Technologies Inc. representative or contact us through our website at [www.keysight.com/find/m9451a](http://www.keysight.com/find/m9451a).

The M9451A-DPD option significantly speeds up DPD/ET test applications that use N7614B Signal Studio Power Amplifier Test software. To simplify porting, M9451A-DPD's application programming interface (API) is very similar to the N7614B API.

The key features include:

1. Digital Pre-Distortion
  - Open or closed loop
  - PA models: Look-up table (LUT) and Memory Order Polynomial.
  - Fast peer-to-peer (P2P) data transfer to/from PXIe signal generator and signal analyzer
2. Envelope Tracking
  - Hardware accelerated envelope tracking waveform generation
  - Supports arbitrary (fractional rate) up-sampling and timing skew of envelope waveform
  - Fast data transfer to arbitrary waveform generator (AWG)

As part of Keysight's RF PA/FEM Characterization & Test, Reference Solution, this combination provides enhanced performance for envelope tracking and digital pre-distortion measurements required in testing modern power amplifiers (PAs) and front-end modules (FEMs). Hardware acceleration provides speed improvement over Keysight's previous host-based Reference Solution, with closed/open loop digital pre-distortion (DPD) and envelope tracking (ET) measurements. The usage of DPD functionality of M9451A module as a part of Keysight RF PA/FEM Characterization and Test, Reference Solution is documented in [Keysight RF PA/FEM Characterization and Test, Reference Solution Configuration Guide](#).

## Concepts

This section describes how Digital Pre-Distortion and Envelope Tracking are used in Power Amplifiers.

## Envelope Tracking (ET) Concept

Envelope tracking is a technology to improve the efficiency level of the PA (power amplifier). It allows the power supply of the PA to be dynamically controlled by the envelope of the RF signal passing through the PA to increase the system efficiency.

[Envelope Tracking \(ET\) Concept \(page 10\)](#)

[Envelope Tracking \(ET\) Concept \(page 10\)](#)

## Reasons to Use Envelope Tracking

For conventional PA, the power supply is designed to be a fixed DC voltage as shown in the below figure. This kind of design has high transmitter efficiency for systems like GSM and GPRS, which use constant-envelope GMSK modulation.

### Conventional PA Block Diagram

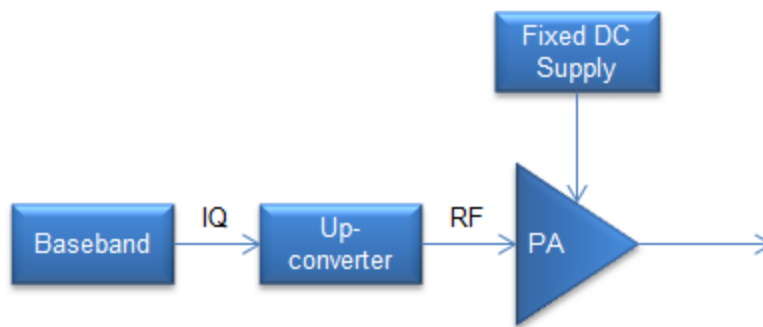

With the pursuit of increased data throughput in limited radio frequency bandwidth, higher spectral efficiency is required. To achieve this, in modern communication systems, more complicated modulation and access schemes are used, like OFDM, CDMA. In these modulation schemes, the signal envelope varies continuously during the transmission. The below figure shows that the LTE signal envelope varies over time. If in this case, the PA still works under constant power supply, it means a loss of efficiency, as the PA is the most efficient at its peak power. At lower power levels, the PA operates below its peak power. As a result, a significant amount of power is dissipated as heat.

### Constant Power Supply for Variable Envelope

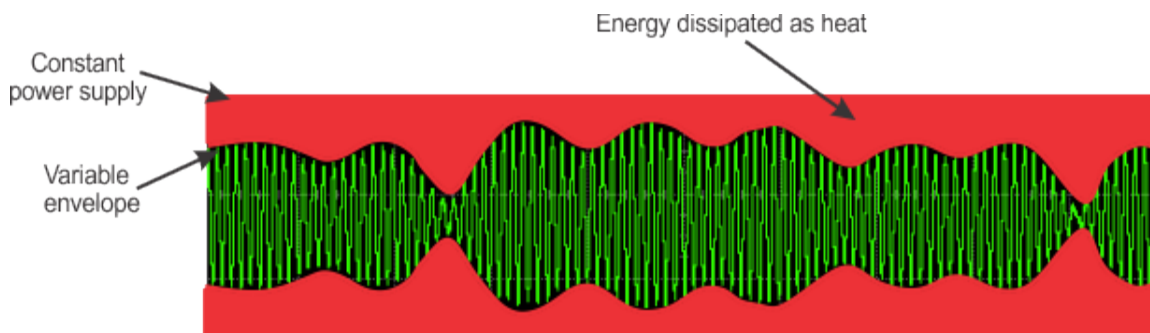

The consequence of the PA inefficiency is very practical. The smart phones will be hotter and their batteries will run out quickly; at the same time, mobile and broadcast network operators need to pay a lot for the wasted energy.

Envelope tracking, is a technique to increase the PA efficiency dramatically.

### Envelope Tracking Basic Concept

The basic principle of envelope tracking, as shown in below figure, is to constantly adjust the supply voltage of the PA according to the envelope of RF input signal so that the PA can always operate at a high efficiency.

### Constant Power Supply for Variable Envelope

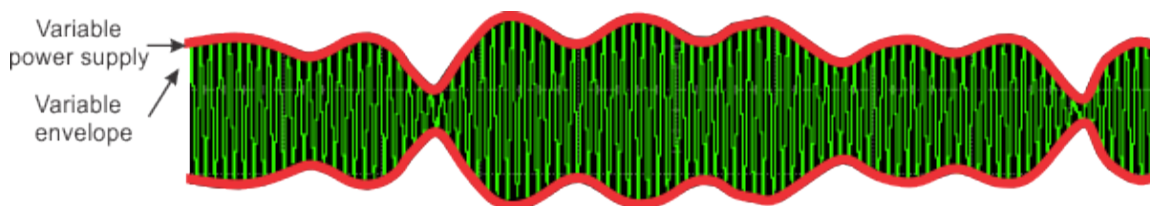

In baseband, envelope detector generates envelope by taking magnitude of IQ, which

is  $\sqrt{I^2 + Q^2}$ . The magnitude of the signal is not the ideal signal for envelope tracking power supply. To obtain the maximum efficiency, the magnitude of the signal is often modified by shaping. A shaping table is then developed to map the signal magnitude to the required voltage supply on the PA. This shaping table determines characteristics of ET system, so system designers spend a lot of time and effort to optimize shaping tables. The shaped envelope is then supplied to Envelope Tracking Power Supply, or ETPS.

### Envelope Tracking PA

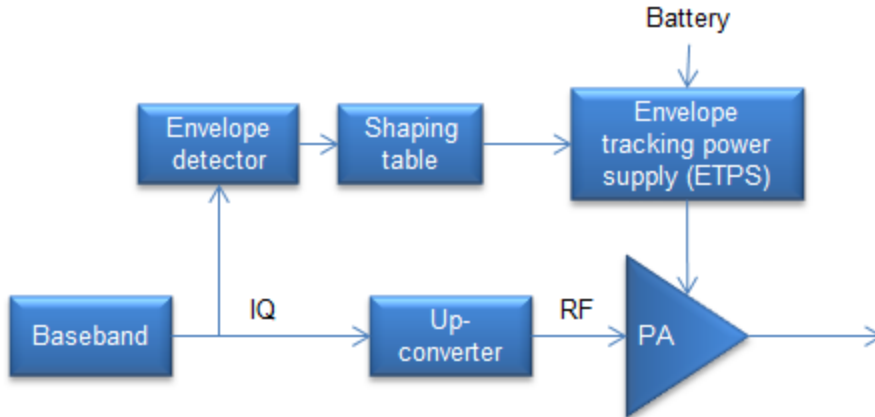

For envelope tracking PA, the envelope tracking power supply and the RF input signal should be aligned strictly in time. Even small time deviations will have substantial influence in the RF output signal, leading to the deterioration of the ACP and EVM.

### Time Alignment

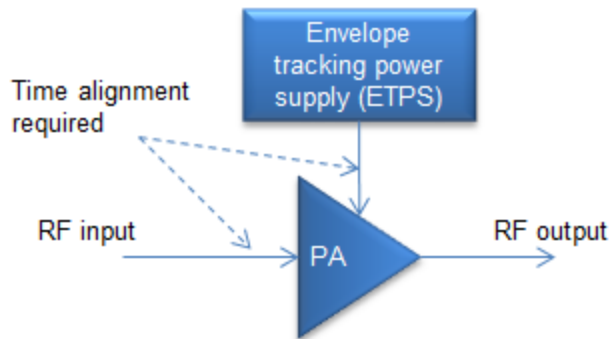

### Digital Pre-Distortion (DPD) Concept

Power amplifiers are essential components in the overall performance and throughput of communication systems, but they are inherently nonlinear. The nonlinearity generates spectral re-growth, which leads to adjacent channel interference and violations of the out-of-band emissions standards mandated by regulatory bodies. It also causes in-band distortion, which degrades the bit-error rate (BER) and data throughput of the communication system.

To reduce the nonlinearity, the power amplifier can be operated at a lower power (that is, "backed off") so that it operates within the linear portion of its operating curve. However, newer transmission formats, such as wideband code division multiple access (WCDMA) and orthogonal frequency division multiplexing (OFDM, WLAN/3GPP LTE), have high peak-to-average power ratios (PAPR); that is, large

fluctuations in their signal envelopes. This means that the power amplifier needs to be backed off well below its maximum saturated output power in order to handle infrequent peaks, which result in very low efficiencies (typically less than 10%). With greater than 90% of the DC power being lost and turning into heat, the amplifier performance, reliability and ongoing operating expenses (OPEX) are all degraded.

### DPD-PA Cascade

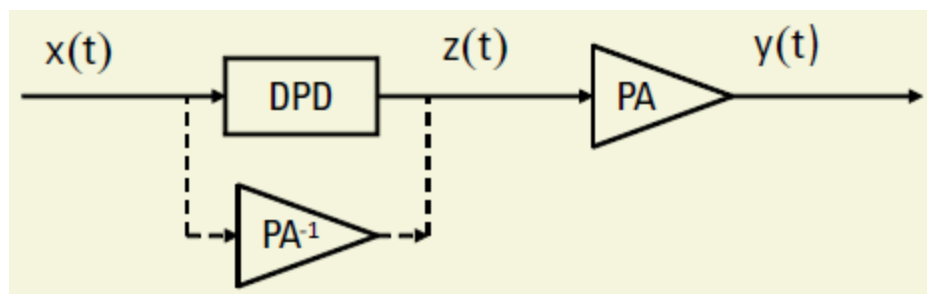

DPD is one of the most cost-effective linearization techniques. It features an excellent linearization capability, the ability to preserve overall efficiency, and it takes full advantage of advances in digital signal processors and A/D converters. The technique adds an expanding nonlinearity in the baseband that complements the compressing characteristic of the RF power amplifier (Figure 1). Ideally, the cascade of the pre-distorter and the power amplifier becomes linear and the original input is amplified by a constant gain. With the pre-distorter, the power amplifier can be utilized up to its saturation point while still maintaining good linearity, thereby significantly increasing its efficiency. From Figure 1, the DPD can be seen as an "inverse response" of the PA. The DPD algorithm needs to model the PA behavior accurately and efficiently for successful DPD deployment.

### DPD Implementation Methods

DPD implementations can be classified into memoryless models and models with memory.

#### Memoryless Models - Look-up Table (LUT)

Memoryless models focus on the power amplifier that has a memoryless nonlinearity, that is, the current output depends only on the current input through a nonlinear mechanism. This instantaneous non-linearity is usually characterized by the AM/AM and AM/PM responses of the power amplifier, where the output signal amplitude and phase deviation of the power amplifier output are given as functions of the amplitude of its current input. Both memoryless polynomial algorithm and Look-Up Table (LUT) based algorithm are two key algorithms for memoryless models.

#### Look-up Table Structure

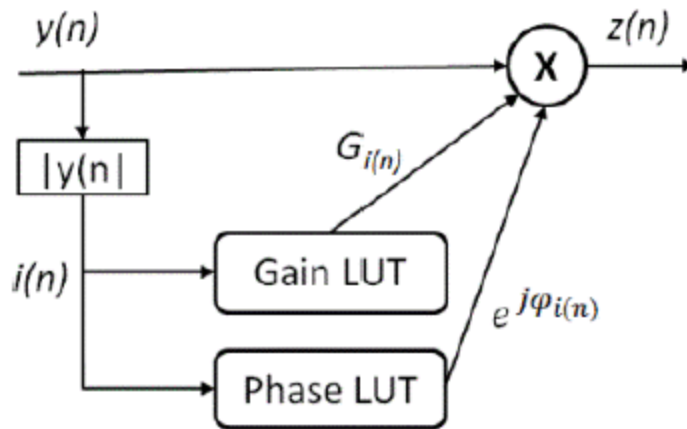

### Memory Models – Memory Polynomial, Volterra

Memory model is commonly used as the signal bandwidth gets wider, such as in WCDMA, mobile WiMAX and 3GPP LTE and LTE-Advanced (up to 100 MHz bandwidth, 5 component carriers of carrier aggregation). For wider bandwidth, power amplifiers begin to exhibit memory effects. This is especially true for those high power amplifiers used in wireless base stations. The causes of the memory effects can be attributed to thermal constants of the active devices or components in the biasing network that have frequency dependent behaviors. As a result, the current output of the power amplifier depends not only on the current input, but also on the past input values. In other words, the power amplifier becomes a nonlinear system with memory. For such a power amplifier, memoryless pre-distortion can achieve only very limited linearization performance. Therefore, digital pre-distorters must have memory structures.

The most important algorithm for models with memory for Digital pre-distortion implementation is Volterra series and its derivatives. The most general way to introduce memory is to use the Volterra series. However, the large number of coefficients of the Volterra series makes it unattractive for practical applications. Therefore, there are several Volterra's derivatives including Wiener, Hammerstein, Wiener–Hammerstein, parallel Wiener structures, and memory polynomial model are popular in digital pre-distorters. The so-called "memory polynomial" is interpreted as a special case of a generalized Hammerstein model and is further elaborated by combining with the Wiener model.

To construct digital pre-distorters with memory structures, there are two types of approaches. One type of approach is to first identify the power amplifier and then find the inverse of the power amplifier directly. This approach is named as direct learning architecture (DLA). However, obtaining the inverse of a nonlinear system with memory is generally a difficult task. Another type of approach is to use the indirect learning architecture (IDLA) to design the pre-distorter directly. The advantage of this type of approach is that it eliminates the need for model assumption and parameter estimation of the power amplifier.

The indirect learning architecture for the digital pre-distorter is shown as following.  
Indirect Learning Architecture

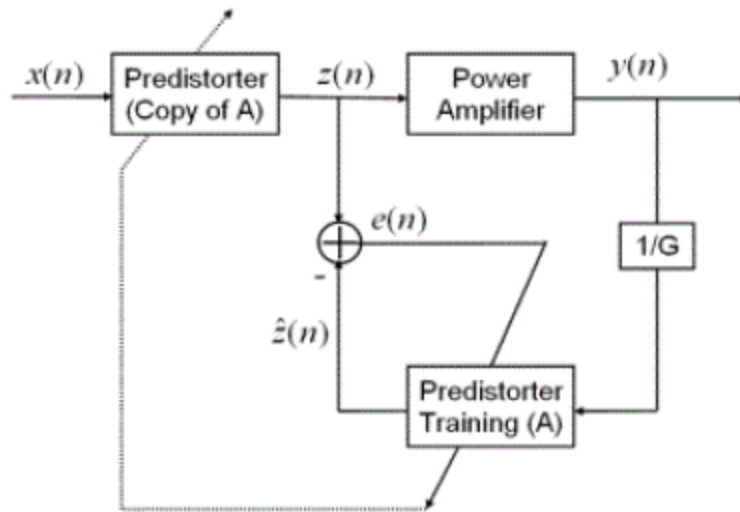

The following figure shows the memory polynomial structure. If  $Q=0$ , the structure in the following figure becomes memoryless polynomial.

Memory Polynomial Structure

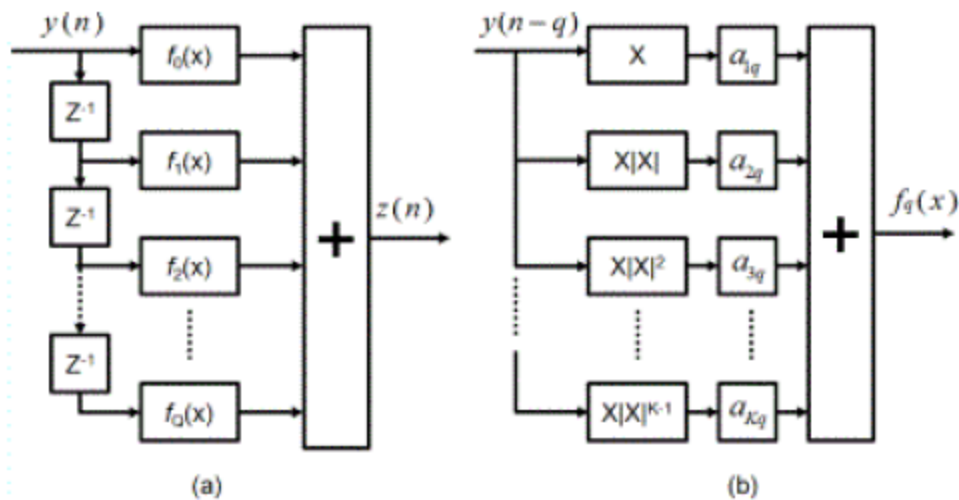

The structure of Volterra series is shown below.

Volterra Series Structure

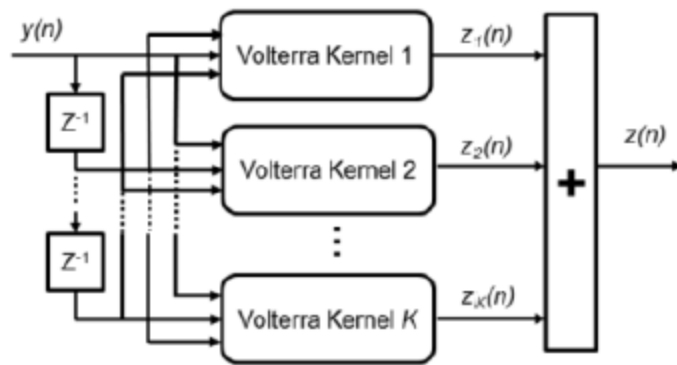



## M9451A-DPD/ET Block Diagram

The following is a block diagram of the Keysight M9451A PXIe Measurement Accelerator with DPD personality and the interfaces to the other test equipment in the system:

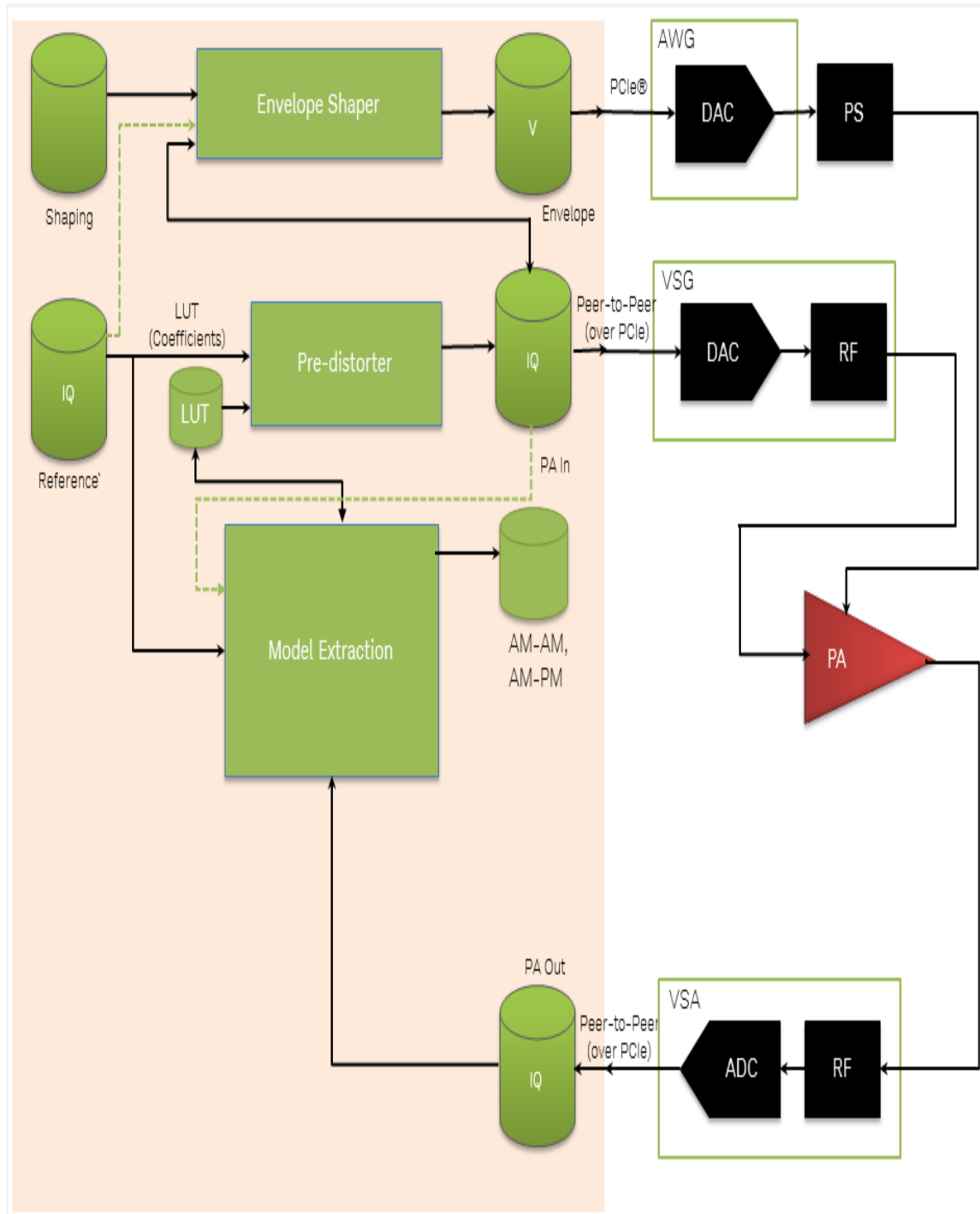

The highlighted box shows the key functions of the digital pre-distortion (DPD) and envelope tracking (ET) gateway in the M9451A PXIe measurement accelerator. The data cylinders are allocated blocks of IQ data in the M9451A memory. The rectangles represent algorithms implemented in the accelerator. The test software controls how data is processed by passing data handles associated with each data cylinder to the API method associated with each algorithm rectangle. Peer-to-peer (P2P) PCI Express® technology is used to achieve fast data transfers between the M9451A memory and the M9381A PXIe vector signal generator (VSG) hardware.

The ideal reference waveform, without pre-distortion, is first loaded into the M9381A PXIe VSG ARB memory and then transferred to the M9451A using P2P. After the model extraction algorithm computes a lookup table (LUT), or other coefficients, the pre-distorter creates a pre-distorted waveform in the PA In cylinder. P2P is used to transfer the pre-distorted waveform data to the VSG ARB memory. P2P PCI Express technology is also used to transfer measurement data from the M9391A or M9393A PXIe vector signal analyzer hardware to the M9451A hardware.

To utilize the M9451A-DPD as part of your test software, example open source code is available as part of the Keysight RF PA/FEM Characterization and Test, Reference Solution. For more information about the Reference Solution, refer

[www.keysight.com/find/solution-padvt](http://www.keysight.com/find/solution-padvt).

## Data Interfaces

### Reference IQ Data

The Reference waveform is the IQ data used in the VSG to generate the RF waveform prior to the application of DPD. This waveform is copied from M9381A VSG waveform memory directly to the M9451A memory using peer-to-peer data transfers. Many of the waveforms used in the VSG are generated with the Keysight Signal Studio Software packages. These waveforms require a license to play in the VSGs and thus the data in the waveforms is encrypted. Encrypted waveforms from the VSG cannot be exported from the M9451A module into an unencrypted format.

The M9381A VSG does not support direct loading of MATLAB data files, so a file conversion process is used to translate the data into a supported file format. The following steps describes the waveform translation process:

- Load the Original File into MATLAB
- Reduce the Sample Rate from the Original 245.76 MHz to a sample rate within the range of the M9381A VSG. Typically, the sample rate is reduced by a factor of 2 using the MATLAB command:  
`y = resample(xBBcf, 1,2);`
- Save the re-sampled data to a MATLAB file using the command:  
`save('C:\Device Files\S00x\[fileName].mat', 'y');`  
The file name used matches the original file name with the "245p76" segment referring to the sample rate replaced by "122p88"

- Use a file conversion tool built from the N7614B Signal Studio for PA Test Software.  
The output of the file conversion tool has the same file name as the original MATLAB waveform, changing the file extension from .mat to .wfm. Files that are generated with the N7614B software include the Signal Studio license for that software package and thus are stored in an encrypted format. At run time, the .wfm waveform file is loaded into the M9381A VSG and then copied to the Keysight M9451A PXIe Measurement Accelerator. Although the data cannot be read from M9451A, the original MATLAB waveform, at 122.88 MHz sample rate, can be loaded into MATLAB. There is no signal processing performed on the waveform data, so the data in the MATLAB file will be identical.

## Measured PA Output Data using Test Equipment

The PA Output is captured as IQ data at the same sample rate as the reference waveform. This data is then copied from the VSA waveform memory to the M9451A waveform memory using peer-to-peer data transfer.

If a copy of the measured PA Output data is needed for other analysis, use VSA driver to also transfer the data into a test program array. For an example, refer [\(page 25\)](#).

## M9451A DPD/ET Measurements

### DPD Output

The DPD process generates a look-up table (LUT model) or memory order polynomial coefficients (memory model) used to pre-distort the reference IQ waveform and also provides access to the AM/AM and AM/PM data used to generate the LUT or coefficients. Both of these data items can be saved. The pre-distorted waveform is copied from the M9451A memory to the VSG waveform memory. The M9451A API includes a method to save the pre-distorted waveform to a secure file, but this capability has not been implemented at this time.

After performing extraction, GetAmAm\_AmPm method can be called to get the AM/AM and AM/PM data, which can be saved to a CSV file. While using the LUT/Memory Polynomial models, the look-up table created by the Extract method and the coefficients created by the Extract method can be saved to a CSV file. The DPD example programs perform these operations.

For the available list of M9451A Example programs, refer [Sample API Programs \(page 24\)](#).

### Envelope Data

The envelope waveform is generated from the Reference IQ waveform or the pre-distorted waveform, the shaping table and two scaling parameters, one for the envelope voltage and one for the magnitude data. The envelope data is generated as 16-bit unsigned integers allowing direct loading into the AWG module. The envelope

scaling factor factors in the gain in the output stage of the AWG and the gain of the envelope tracking power supply. The magnitude scale factor is applied to the Reference IQ data before the value is looked up in the shaping table. When the magnitude scale factor is 1, the peak value of the magnitude will produce the maximum voltage in the shaping table. Setting the magnitude scale factor to values between 0 and 1 causes a smaller portion of the shaping table to be used. The envelope generator supports arbitrary (fractional) up-sampling, and fractional-sample time delay.

# M9451A-DPD/ET Specifications

The specifications describe the warranted performance of calibrated instruments. Specifications include guardbands to account for the expected statistical performance distribution, measurement uncertainties and changes in performance due to environmental conditions. All specifications and characteristics apply over the operating environment as outlined in the Environmental Characteristic table. Additionally, the following conditions must be met:

- Instrument should be stored in stable surrounding environment temperature between 0°C to 55°C for 15 minutes before being turned on.

Data sheets contain specifications for current production modules. The Data Sheet Guide for M9451A is included on the Keysight M9451A DPD/ET PXIe Measurement Accelerator Source Software and Product Information CD (M9451-10001). The Data Sheet for the M9451A can also be found at [www.keysight.com/find/m9451a](http://www.keysight.com/find/m9451a).

The following are the M9451A DPD/ET PXIe Measurement Accelerator Specifications:

## Digital Pre-Distortion

<b>Supported DPD models</b>	Look-up table, Memory order polynomial
<b>Minimum waveform length</b>	256 samples
<b>Maximum waveform length</b>	1,512,286 samples
<b>Extract timing skew tolerance</b>	-8 to +8 samples
<b>Results available</b>	AM-AM and AM-PM, Delta-EVM

## DPD Look-up table model

<b>Table size</b>	2 to 256. Default value set to 128
<b>Polynomial Order of curve-fit</b>	3 to 12. Default value set to 5
<b>Results available</b>	LUT and D-EVM

## DPD Memory order polynomial model

<b>Memory order, Q</b> (number of prior samples in the model)	0 to 3. Default value set to 1
<b>Non-linear order, K</b> (polynomial order)	1 to 9. Default value set to 5
<b>Model identification algorithms</b>	QR factorization or Singular Value Decomposition (SVD)
<b>Results available</b>	Polynomial coefficients and D-EVM

## Envelope Tracking

<b>Delay (in seconds) of envelope</b>	Fractional, range depends on sample rate and number of samples
<b>Oversampling Ratio</b>	Fractional, 1.0 to 1000.0. Default value set to 3.0
<b>Magnitude Scale Factor</b>	0.0 to 10.0. Default value set to 1.0
<b>Envelope Scale Factor (volts per DAC)</b>	1 microVolt to 1 Volt. Default value set to 10.0/65536.0

count)

**Envelope Reference Voltage**

Range depends on scale factors

# Programming M9451A-DPD/ET option using .NET and IVI APIs

The M9451A PXIe DPD/ET Measurement Accelerator includes a full Microsoft .NET-based application programming interface (API) to automate the entire signal configuration and playback process in a programming environment of your choice.

For programming documentation on M9451A DPD/ET .NET API, please refer to the respective documentation available at **Start Menu > All Programs > Keysight > M9451A DPD/ET Accelerator API Reference Guide**.

For programming documentation on the M9451A IVI driver, please refer to the respective documentation available at **Start Menu > All Programs > Start Menu > All Programs > Keysight Instrument Drivers > KtMMAcc > KtMMAcc Driver Help**.

**Using API Help (page 23)** provides information on accessing API help, usage requirements, and references.

**Sample API Programs (page 24)** provides information about API examples included with the software that can be modified for your application.

## Using API Help

API commands for controlling the M9451A-DPD/ET PXIe Measurement Accelerator are documented in the M9451A Documented Class Library (M9451A DPD/ET API Reference Guide.chm). This help file is located in the following directory: <YourDrive :> \Program Files (x86)\Keysight\MMAcc.

Many of the links in the API help require the Microsoft Visual Studio .NET integrated development environment (IDE). Without the IDE, these links appear broken. Download the IDE to repair the links.

## Example Programs

**Sample API Programs (page 24)** are placed in the a folder that can be accessed by clicking **Start Menu > All Programs > Keysight > MMAcc > Open DPD Examples** after you install the software. You can use these samples as a starting point to develop your own API programs. Copy these programs to a work folder before modifying them.

## Numeric Format

This software recognizes only US style numeric format, using "." for the floating point radix.

## Language Requirements

You must set the API locale to "en-US" using the following commands prior to starting the user main routine:

```
Thread.CurrentThread.CurrentCulture = new CultureInfo("en-US"); // Sets the culture to English (US)
```

```
Thread.CurrentThread.CurrentUICulture = new CultureInfo("en-US"); // Sets the UI culture to English (US)
```

## References

The Microsoft.NET home page.

Developing Microsoft.NET Skills.

Troelsen, Andrew. C# and the .NET Platform. New York: Apress, 2001.

## Sample API Programs

The Keysight M9451A PXIe Measurement Accelerator includes several example programs that illustrate the DPD measurements using the M9451A Accelerator and the shared usage of the M9391 or M9393 IVI Driver session.

The example programs can be accessed via **Start Menu > All Programs > Keysight > MMAcc > Open DPD Example Folder....** Following are the example folders:

Folder Name	Sub-Folder Name	Language	Location
VS.NET\CSharp	CS_PredistortExample	.NET (C#)	<a href="#">Sample API Programs (page 24)</a>
VS.NET\CSharp	CS_LutDpdExample	.NET (C#)	<a href="#">Sample API Programs (page 24)</a>
VS.NET\CSharp	CS_LutDpdExampleNoPTP	.NET (C#)	<a href="#">(page 25)</a>
VS.NET\CSharp	CS_ MemoryModelDpdExampleNoPTP	.NET (C#)	<a href="#">Sample API Programs (page 24)</a>
VS.NET\CSharp	CS_EnvelopeTrackingExample	.NET (C#)	<a href="#">Sample API Programs (page 24)</a>
VS.NET\CSharp	CS_DpdFileViewer	.NET (C#)	<a href="#">Sample API Programs (page 24)</a>

To view the code, open the solution files (.sln) using the Microsoft Visual C# .NET IDE, or a text editor, such as Notepad.



## C# (C Sharp) Example Programs

### CS\_PredistortExample – Digital Pre-Distortion Example

This Digital Pre-Distortion Example program provides basic program to use the M9451A PXIe Measurement Accelerator to apply Digital Pre-Distortion (DPD) to a waveform in a M9381 VSG modules. This program is simpler than other examples because it only applies pre-distortion based on a LUT file that is an input to the program.

This program requires a M9451A PXIe Measurement Accelerator with DPD option and Vector Signal Generator (VSG). This program supports the usage of the M9381 PXIe modules (version 2.0 or later) as the VSG.

### CS\_LutDpdExample – Look-up Table DPD example, using peer-to-peer data transfer

This look-up Table DPD Example shows how to use the DpdAccelerator API to perform a measurement, extract a LUT, apply digital Pre-Distortion (DPD), and re-measure the signal after the application of DPD algorithm.

This program requires a M9451A Measurement Accelerator with DPD option, Vector Signal Generator (VSG) and Vector Signal Analyzer (VSA). This program supports the usage of M9381 PXIe modules (version 2.0 or later) as the VSG and either the M9391A (version 2.0 or later) or M9393A (version 1.2 or later) modules as the VSA.

### CS\_LutDpdExampleNoPTP – Look-up Table DPD example, not using peer-to-peer data transfer

This example is similar to CS\_LutDpdExample with a difference that it transfers VSA data by reading into a host program and writing to the accelerator module directly. However, in this case, the host transfers are slower but compatible with older VSA drivers.

This program requires a M9451A Measurement Accelerator with DPD option, Vector Signal Generator (VSG) and Vector Signal Analyzer (VSA). This program supports the usage of the M9381 PXIe modules (version 2.0 or later) as the VSG and either the M9391A or M9393A modules as the VSA.

### CS\_MemoryModelDpdExample – Memory Model DPD example

This memory order polynomial model DPD Example shows how to use the DpdAccelerator API to perform a measurement, extract coefficients, apply digital Pre-Distortion (DPD), and re-measure the signal after the application of DPD algorithm.

This program requires a M9451A Measurement Accelerator with DPD option, Vector Signal Generator (VSG) and Vector Signal Analyzer (VSA). This program supports the usage of

M9381 PXIe modules (version 2.0 or later) as the VSG and either the M9391A (version 2.0 or later) or M9393A (version 1.2 or later) modules as the VSA.

### CS\_EnvelopeTrackingExample – Envelope Tracking example

This example shows how to use the DpdAccelerator API to generate an envelope waveform to transfer to an Arbitrary Waveform Generator (AWG) to support Envelope Tracking.

This program requires a M9451A Measurement Accelerator with DPD option, Vector Signal Generator (VSG) and Vector Signal Analyzer (VSA), and a compatible Arbitrary Waveform Generator (AWG).

### CS\_DpdFileViewer – Graphical Viewer Utility

This utility reads LUT and AM-AM/AM-PM files, and graphically displays the data. It can be used to view the files created by the above examples, or to view example files typically installed to <Your Drive:>\Program Files(x86)\Keysight\MMAcc\Dpd Examples\Example Waveforms.

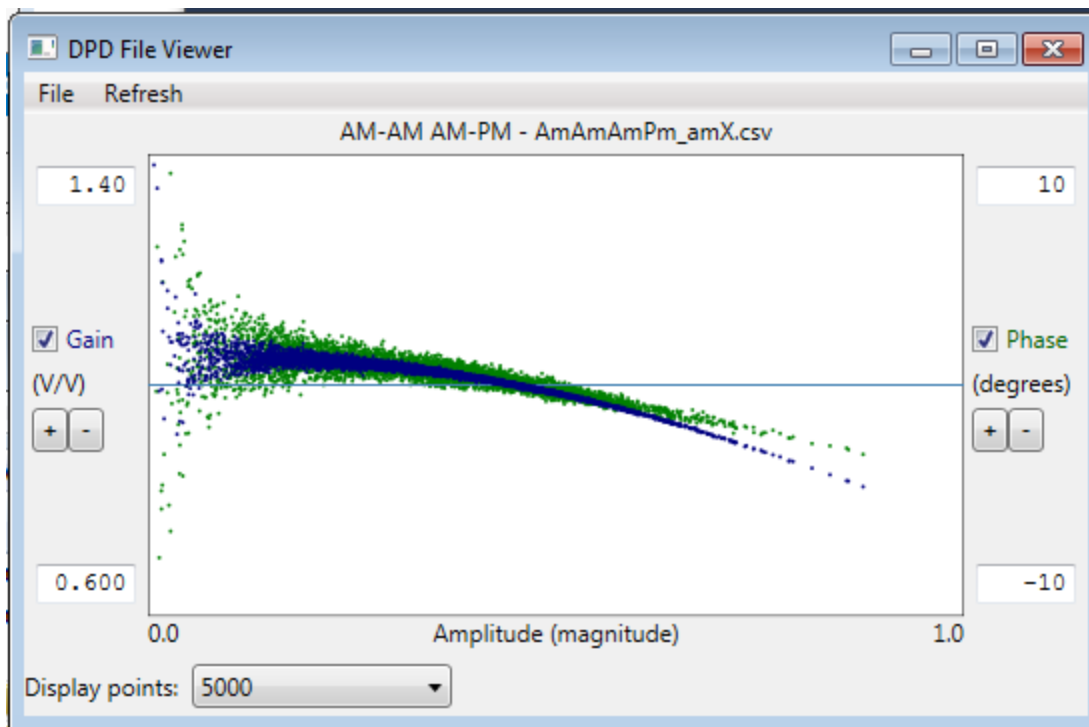

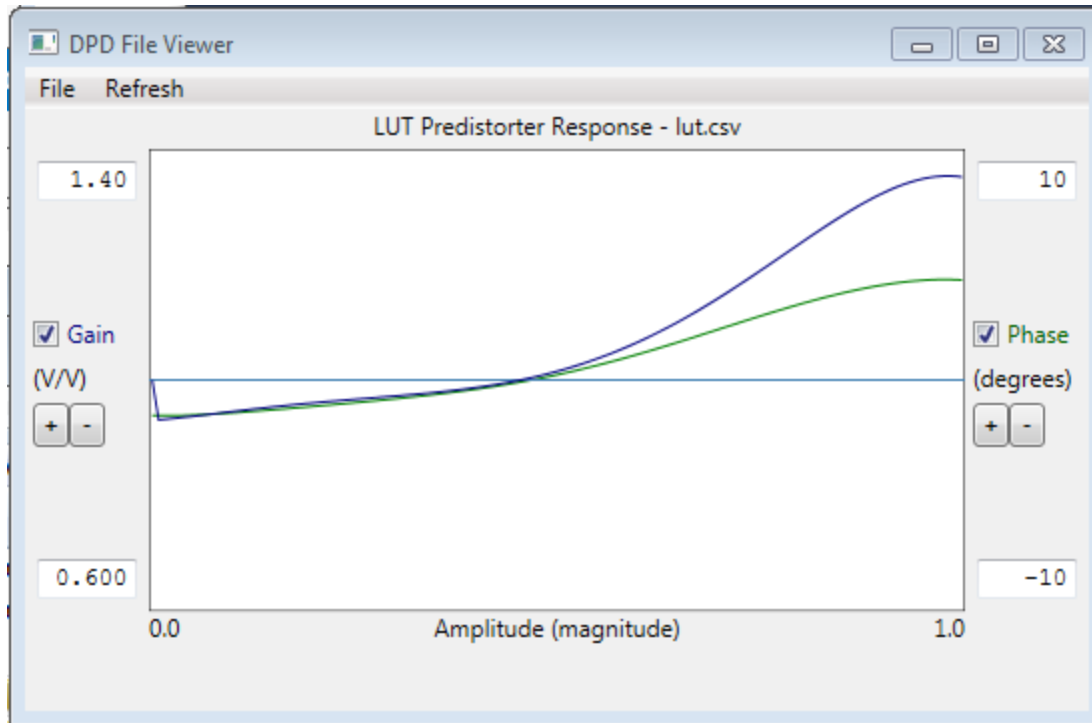



# Troubleshooting M9451A DPD/ET Measurement Accelerator

Common Problem	Root Cause	Workaround
PA Out signal power too low	This error indicates that the power is low in data transferred from the VSA, which is a measurement of the power amplifier's output	In case of such an error, check the VSA driver settings for expected input power, check cables, verify the power amplifier is operating and use the VSA soft front panel for additional troubleshooting.
PA Out and Reference signal correlation too low	This error is reported when the two signals have low correlation. The correlation range is +/- 8 samples of timing difference, so triggering problems can cause this error. Corrupt PA Out measurement data can cause this error.	Use triggering on the VSA and VSG to time-align the measured PA Out signal with the reference waveform.
Fine Synchronization failed to converge	This error is reported when the process to synchronize the PA Out waveform with the reference fails to converge properly.	Increase the length of the PA Out acquisition (10,000 samples is recommended).
License protected data can not be saved to a CSV file OR Not supported for license protected waveforms	These errors occur when calling <code>IDataHandle.SaveToCsvFile()</code> or <code>IDataHandle.GetDataArray()</code> , if the data is license unprotected, or may be license protected. All data transferred into accelerator module memory by peer-to-peer is assumed to be license protected. This can result in this error unexpectedly occurring when saving a waveform that was not originally license protected, but was transferred using peer-to-peer.	To work around this, load the data using <code>LoadFromCsvFile()</code> instead of peer-to-peer.



# Optimizing Performance

The following measures can be taken to optimize the performance of the M9451A-DPD PXIe Measurement Accelerator:

- **Waveform Selection** - DPD techniques are intended for use with high peak-to-average waveforms, so DPD LUT extractions should be performed with waveforms having PAR typical for the DUT application. DPD also works best if the peaks are not too rare, so it is recommended to prepare the reference waveform file by performing Crest Factor Reduction (CFR), or use a test waveform designed specifically to stimulate distortion mechanisms. Since the accelerator performs time alignment using correlation techniques, DPD test waveforms must have low auto correlation. DPD using a periodic waveform (such as a sine) is not supported.
- **Waveform Length** - Waveform length should be short to optimize speed, but long enough to give good results. Extract processing time increases with increasing length of the "PA Out" data acquired by the VSA. The DPD accelerator supports using a long "PA In" waveform (for example, an entire frame), with a short PA Out acquisition (just the beginning of the frame). For good Extract() results and low Delta-EVM, the length of the PA Out acquisition should be at least 10,000 samples. More than 100,000 samples may be optimum for highly oversampled waveforms.
- **Oversampling** - DPD often requires significant oversampling so several adjacent channels are within the measurement bandwidth. 4x oversampling is recommended. The measurement accelerator does not perform oversampling of DPD waveforms, so oversampling must be performed when the reference waveform file is prepared.
- **Burst Waveforms** - To perform DPD with RF burst waveforms typical of time domain duplex (TDD) formats, it is mandatory to configure the accelerator to Extract() only during the burst on time. If the burst is at the beginning of the reference waveform, just limit the VSA acquisition to the length of the burst. If the burst is delayed from the start of the reference waveform, also set the OffsetReference parameter to the number of samples to skip, and setup the VSA trigger delay to skip the same number of samples during the acquisition.



This information is subject to change  
without notice.  
© Keysight Technologies 2015  
Edition 2, August, 2015  
Printed In Malaysia



M9451-90004  
[www.keysight.com](http://www.keysight.com)